

# Product data sheet

## Fire brigade lock

ESDFB02R

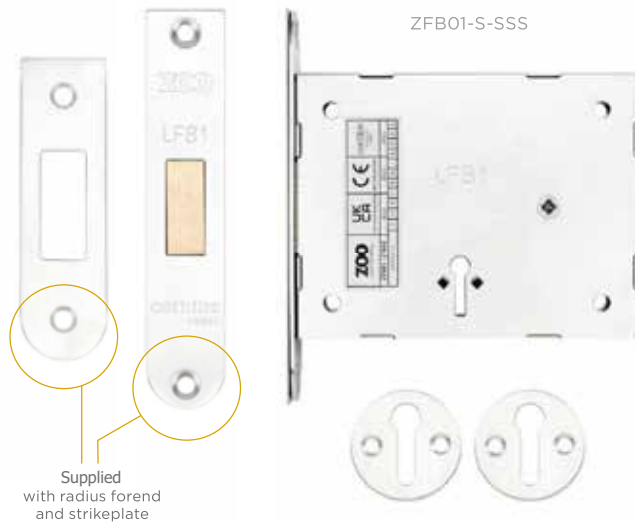

Code	Description	Finish
ZFB02-R-SSS	Mortis London Fire Brigade Lock (Key Profile 02), Radius Forend and Strike, c/w Escutcheons	SSS
ZFB02K	Spare Key t/s London Fire Brigade Lock (Key Profile 02)	NP - Nickel Plate
ZFB001-SSS	Escutcheon pack t/s ZFB01/ZFB01/ZFB02 Series Fire Brigade Lock	SSS

### Product features

- 51.5mm backset.
- Double forend (steel inner, stainless steel outer forend).
- Supplied with lever key profile escutcheons.

### Performance testing

- Successfully tested in accordance with the requirements of BS EN 12209: 2003.

### Forend options

- Radius.

### Finishes

- Satin stainless steel brackets (SSS).

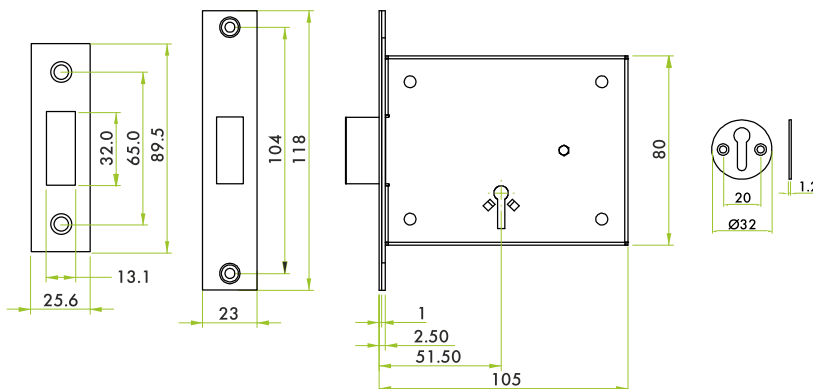

Drawing not to scale